

4

3

2

1

IMPORTANT:  
LARGER OD OF THE SPRING PERCH  
GOES AGAINST THE RETAINING RING

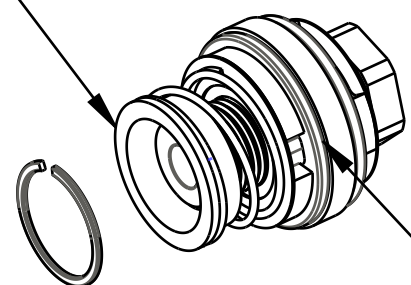

IMPORTANT:  
ENSURE VALVES ARE NOT  
PINCHED DURING ASSEMBLY

DETAIL A  
SCALE 2:1

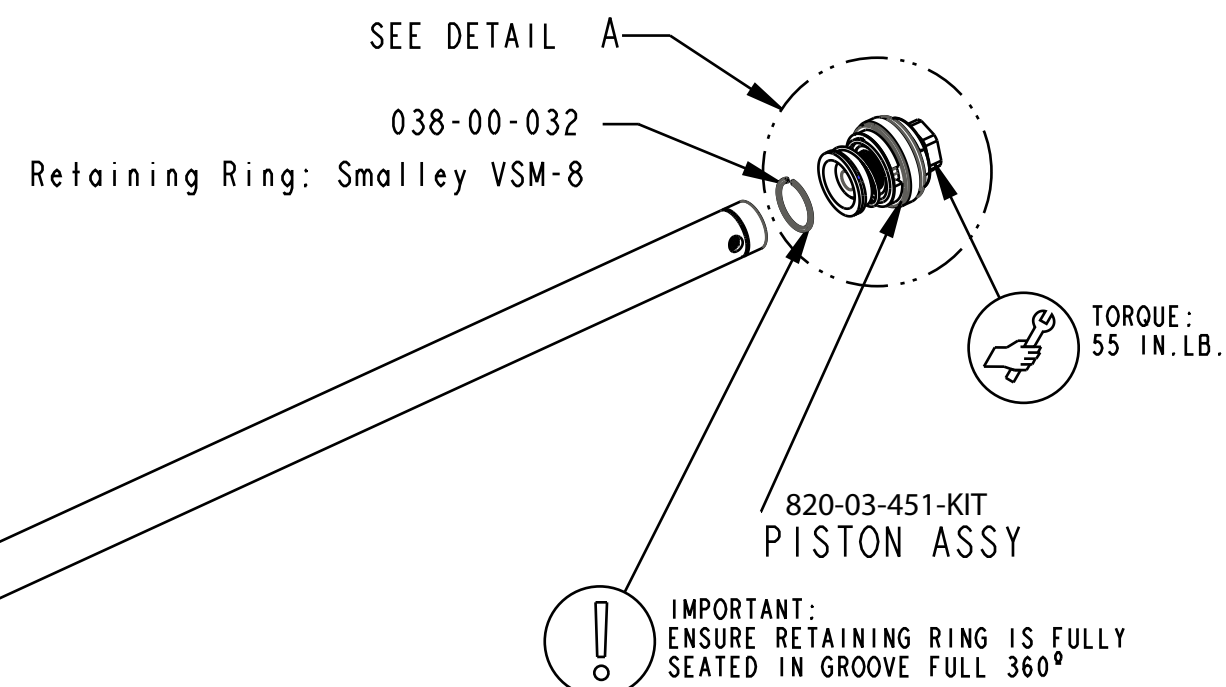

039-00-326  
Spring: Rebound Needle, Stiff, FIT CTD

210-22-441  
Needle, Rebound, Smaller ID Damper Shaft, 010 RL-RLC

DAMPER TUBE

REBOUND TUBE

GREASE:  
THIN LAYER OF SLICK HONEY  
ON BULLET TOOL

TORQUE:  
55 IN.LB.

SEALHEAD

REBOUND ADJUSTER

IMPORTANT:  
ENSURE RETAINING RING IS FULLY  
SEATED IN GROOVE FULL 360°

TORQUE:  
55 IN.LB.

820-03-451-KIT  
PISTON ASSY

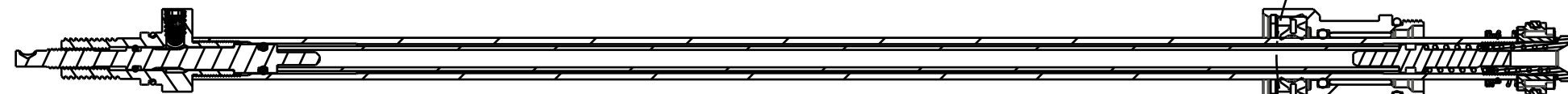

SECTION A-A

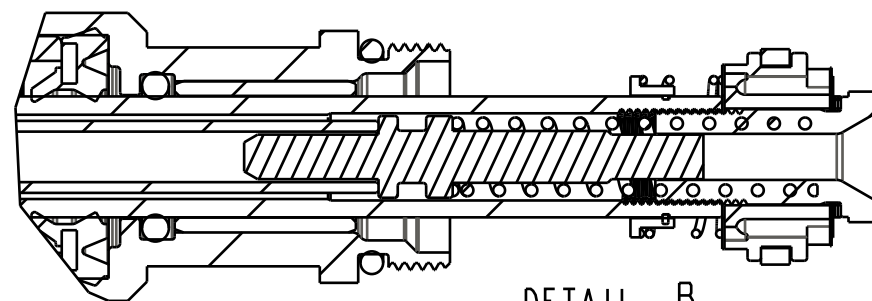

DETAIL B  
SCALE 2:1

SEE DETAIL B

**FOX** FOX Factory, Inc. Ph 831-768-1100  
130 Hangar Way, Watsonville, CA 95076 USA Fax 831-768-9312

TITLE  
**2015 32 FIT iRD  
Damper Shaft Assy**

SIZE DWG. NO.

**C**

PLOT SCALE 0.85:1

SHEET 1 OF 1

PROPRIETARY  
THIS DOCUMENT CONTAINS CONFIDENTIAL, PROPRIETARY INFORMATION  
THAT IS FOX PROPERTY. DO NOT DISCLOSE TO OR DUPLICATE  
FOR OTHERS EXCEPT AS AUTHORIZED BY FOX.

4

3

2

1